

Product Cut Sheet: 1" x 1" Contractor Aluminum Mini-Blind System

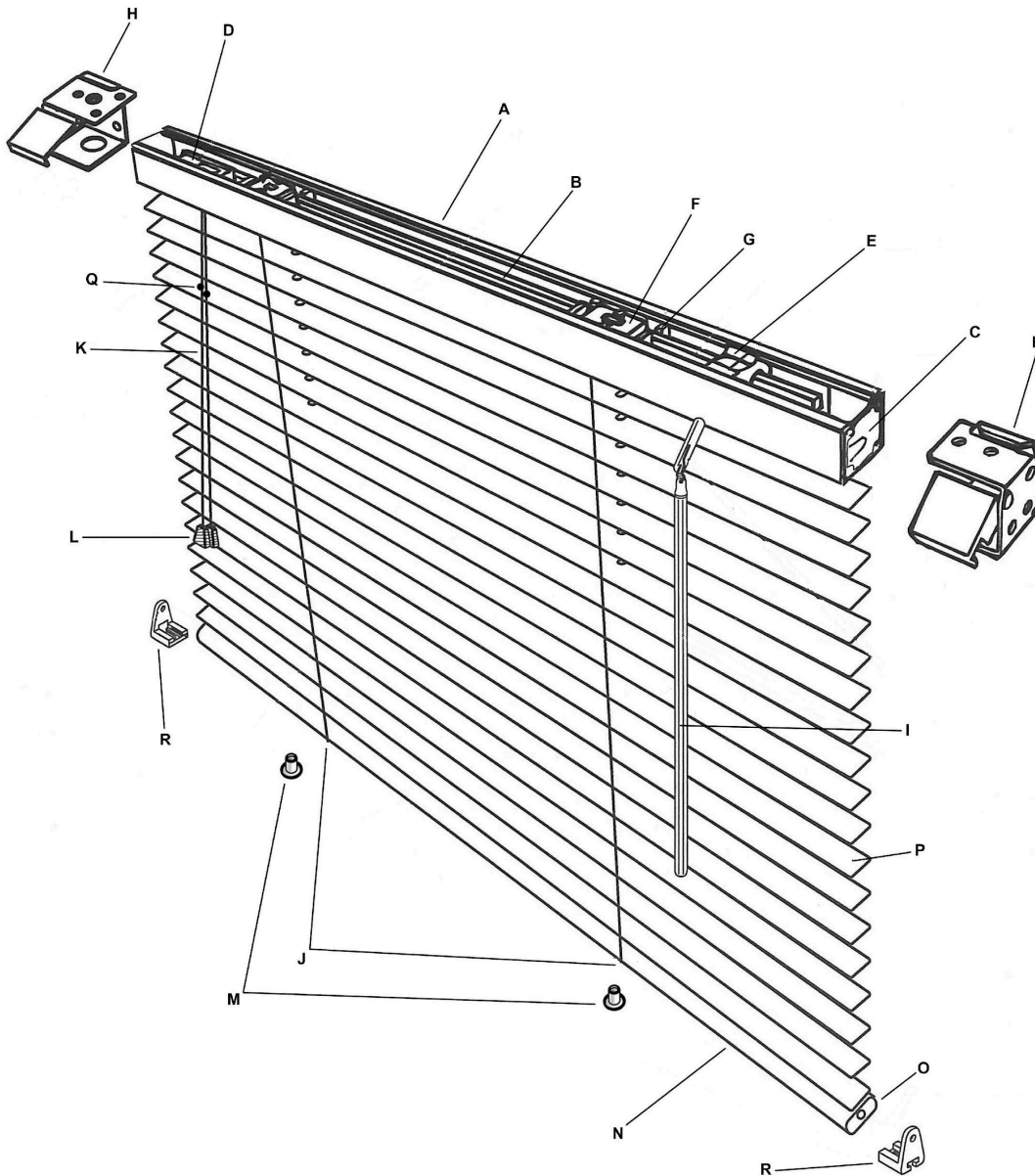

Parts:

- | | |
|-----------------------------------|----------------------------------|
| A) Headrail – Steel | J) Cord Ladder |
| B) Pinion Rod (Tilt Rod) – Square | K) Lift Cord 1.4mm |
| C) End Stiffeners | L) Cord Tassels |
| D) Cord Lock | M) Bottomrail Plugs |
| E) Wand Tilter | N) Bottomrail – C Shape |
| F) Tape Drum (Ladder Drum) | O) Bottomrail End Caps |
| G) Tape Drum Support (Cradle) | P) Slats |
| H) Box Installation Bracket | Q) Cord Safety Rings |
| I) Wand – Clear Hexagonal | R) Hold Down Brackets - Optional |

System Features:

- Heavy Duty Metal and Plastic Components
- Wand Tilter has a metal stem making it the strongest tilter in the industry

Product Cut Sheet: 1" x 1" Contractor Aluminum Mini-Blind System

Blind Options:

- Contractor Mini-Blind – 1" x 1" Headrail with 6-Gauge Aluminum Slats

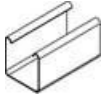

Headrail:

- Polyester baked enamel – color coordinated
- Phosphate treated steel – 1" x 1" high
- Wall thickness – 0.024" (before paint)

Valance Options: *(Color Coordinated)*

- Single slat valance
- Double slat valance
- Deluxe double slat valance



Bottomrail: *(Color Coordinated)*

- Steel – C shape
- Phosphate treated steel
- Wall thickness – 0.024" (before paint)
- Clear plastic end caps

Tilt Controls:

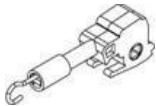

Wand Tilt Option

- The stem of the tilt mechanism are made of steel providing superior durability
- The worm and gear arrangement is entirely enclosed inside an acetal thermoplastic housing

Control Locations: *(Restrictions may apply)*

- Standard: Tilter – Left / Lift Cords – Right
- Reverse: Tilter – Right / Lift Cords – Left
- Same Left: Tilter – Left / Lift Cords – Left
- Same Right: Tilter – Right / Lift Cords – Right



Lift Control (Cord Lock):

- Snap-in design incorporates a stainless steel wear guard over which cords pass
- Incorporates a "Crash Proof" safety feature that locks the blind automatically upon release of cords

Other Headrail Channel Hardware:

- Headrail components are made of a combination of metal and low friction acetal thermoplastics
- Snap-in design of components allows for quick and easy repair if necessary



Cord Ladder: *(Color Coordinated)*

- Polyester braided cord ladders are designed to ensure proper control with adequate overlap of slats when in the closed position

Cord Ladder Spacing:

- Maximum spacing between rout holes is 20"
- Options:
 - Builder Ladder: 22.5mm (13.5 Slats/Ft.)
 - Contract Ladder: 21.5mm (14.2 Slats/Ft.)
 - Classic Ladder: 19.5mm (15.7 Slats/Ft.)
 - Privacy Ladder: 18.0mm (16.9 Slats/Ft.)*Privacy ladder features an offset route hole that provides for increased light blocking.*



Lift Cords: *(Color Coordinated)*

- 1.4mm Polyester braided cords designed for lifting and lowering the blind

Mounting Hardware:

- Universal box brackets (color coordinated)
- Center supports on blinds wider than 60"
- Extension brackets (when requested)
- Hold down brackets (when requested)

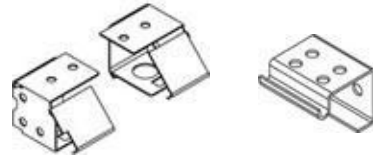

Size Recommendations:

- Minimum Width – 9"
- Minimum Drop – 9"
- Maximum Width – 96"
- Maximum Drop – 96"

The sizes listed above are merely recommendations. Blinds may be ordered larger if required. Optional 2 or 3 blinds on a single headrail are available as well.

